

- For a detailed electronic manual, please visit www.mi.com/global/service/userguide

- For more details, scan the QR code to get the e-guide.



xiaomi Robot Vacuum X20+ User Manual



C102-EU-S00
12/2023



Safety Information

Read this manual carefully before use, and retain it for future reference.

Usage Restrictions

- This product is for floor cleaning in a home environment only. Do not use it outdoors, on non-floor surfaces, or in a commercial or industrial setting.
- This appliance can be used by children aged from 8 years and above and persons with reduced physical, sensory or mental capabilities or lack of experience and knowledge if they have been given supervision or instruction concerning use of the appliance in a safe way and understand the hazards involved. Children shall not play with the appliance. Cleaning and user maintenance shall not be made by children without supervision.
- This appliance contains batteries that are only replaceable by skilled persons.
- Children shall not play with this product. Ensure children and pets are kept at a safe distance from the robot vacuum while it is operating.
- If the cord set is damaged, it must be replaced by a special cord set available from the manufacturer or its service agent.
- Do not use the robot vacuum in an area suspended above ground level without a protective barrier.
- Do not place the robot vacuum upside down. Do not move the robot vacuum by using its LDS laser

sensor cover, cover, or bumper as a handle.

- Use the robot vacuum in environments with an ambient temperature above 0°C and below 40°C. Make sure there is no liquid or sticky substance on the floor.
- Do not install, charge, or use this robot vacuum outdoors, in bathrooms, or near a pool.
- A hazard may occur if the appliance runs over the supply cord.
- Remove fragile or small items from the floor to prevent the robot vacuum from bumping into and damaging them.
- Do not place children, pets, or any item on top of the robot vacuum regardless of whether it is stationary or moving.
- Keep hair, fingers, and other body parts away from the suction opening of the robot vacuum.
- Do not use the robot vacuum to clean any burning substances.
- Do not vacuum up hard or sharp objects.
- The plug must be removed from the socket-outlet before cleaning or maintaining the appliance.
- Do not wipe the robot vacuum or the omni station with a wet cloth or rinse them with any liquid. After cleaning washable parts, fully dry the parts before reinstalling and using them.
- Make sure the robot vacuum is turned off when being transported and kept in its original packaging if possible.

-
- Please use this product in accordance with the instructions in the user manual. Users are responsible for any loss or damage arising from improper use of this product.

Batteries and Charging

WARNINGS:

- Do not use any third-party battery, cord set, or omni station. The robot vacuum can only be used with the model JZ2302 omni station.
- No action needed from users to shift the omni station between 50 Hz and 60 Hz, and the product can adapt itself for both 50 Hz and 60 Hz.
- Do not dismantle, repair, or modify the battery or the omni station on your own.
- Do not place the omni station near a heat source.
- Do not use a wet cloth or wet hands to wipe or clean the omni station's charging contacts.
- If the robot vacuum will not be used for an extended period, fully charge it, then turn it off and store in a cool, dry place. Recharge the robot vacuum at least once every 3 months to avoid over-discharging the battery.
- Do not expose the appliance or battery to excessive temperatures.
- Be aware of the risk of terminals of the battery-operated appliance or battery being short-circuited by metal objects.

- The lithium-ion battery pack contains substances that are hazardous to the environment. Before disposing of the robot vacuum, please first remove the battery pack, then discard, or recycle it in accordance with local laws and regulations of the country or region it is used in.
- Do not damage the battery when removing it to avoid short circuits or liquid leakage. If the battery leaks, keep the fluid from touching your skin or clothes, and wipe it away immediately with a dry cloth. Then send the battery to an appropriate recycling facility or the designated after-sales service team to properly dispose of it.
- When removing the batteries from the product, it is better to use up the batteries and make sure your product is disconnected from power.
 - 1). Uninstall the screw on the bottom, then remove the cover.
 - 2). Unplug the battery connector, then remove the batteries. Do not damage the battery case to avoid any risk of injuries.
 - 3). Return the batteries to a professional recycling organization.
 - The battery must be removed from the appliance before it is scrapped.
 - The appliance must be disconnected from the supply mains when removing the battery.
 - The battery is to be disposed of safely.

Laser Safety Information

- The laser sensor in this product meets the IEC 60825-1: 2014 Standard for Class 1 laser products. Please avoid direct eye contact with it during use.



For indoor use only.

EU Declaration of Conformity

Hereby, Dreame (Tianjin) Information Technology Co., Ltd. declares that the radio equipment type C102 is in compliance with Directive 2014/53/EU. The full text of the EU declaration of conformity is available at the following internet address: <http://www.mi.com/global/service/support/declaration.html>
For detailed e-manual, please go to www.mi.com/global/service/userguide

Product Overview

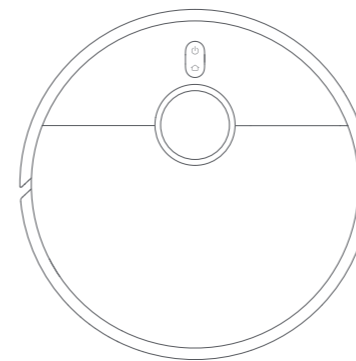

Robot Vacuum

Note: Illustrations of product, accessories, and user interface in the user manual are for reference purposes only. Actual product and functions may vary due to product enhancements.

Accessories

Pre-installed Accessories



Brush

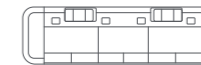

Brush Cover

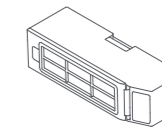

Dust Compartment



Filter
(Pre-installed on the dust compartment)

Other Accessories



Side Brush

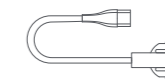

Cord Set



Mop Pad Holder × 2

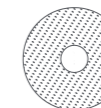

Mop Pad × 2
(Pre-installed on the mop pad holder)

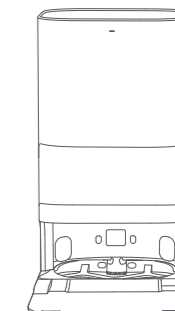

Omni Station
(disposable bag, clean water tank, dirty water tank, washboard base extender, washboard included)

Robot Vacuum and Sensors

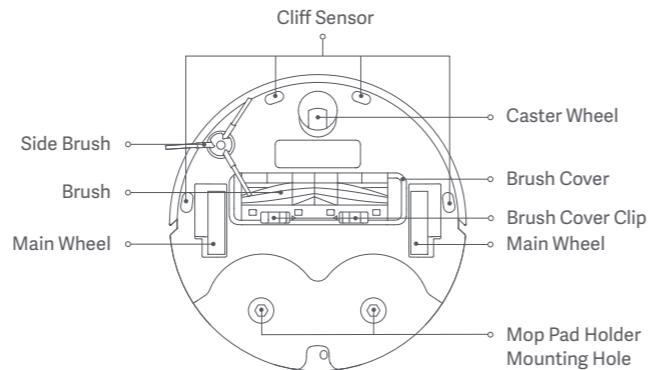
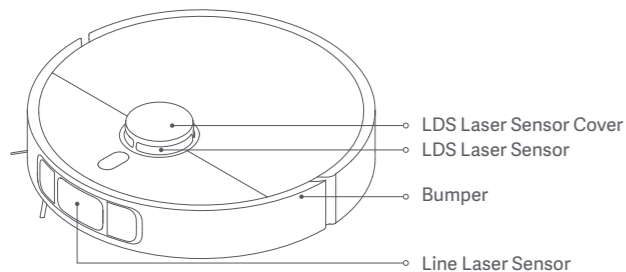

- Press and hold for three seconds to turn on or off
Press to start cleaning or pause while turned on
- Press to pause while running
Press while paused to return the robot vacuum to the omni station for charging
Press to stop docking while returning to the omni station
Press and hold for three seconds to enable or disable the child lock

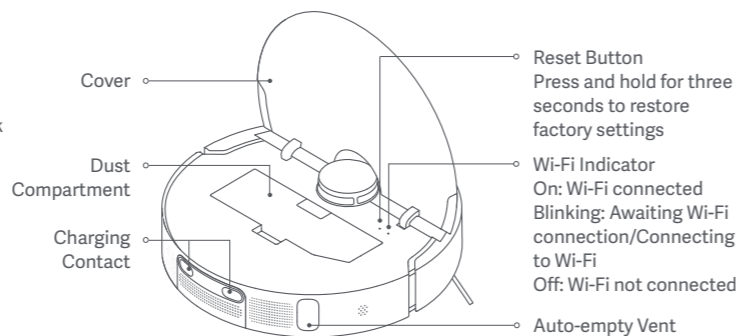

Indicator

- White: Cleaning/Cleanup completed/Fully charged
- Blinking white: Returning to charge/Repositioning/Updating firmware/Awaiting Wi-Fi connection/Connecting to Wi-Fi
- Breathing white: Charging (medium/high battery level)
- Blinking orange: Robot vacuum error
- Orange: Wi-Fi disconnected
- Breathing orange: Charging (low battery level)

Omni Station

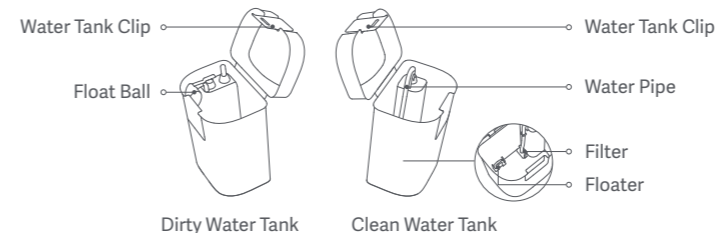
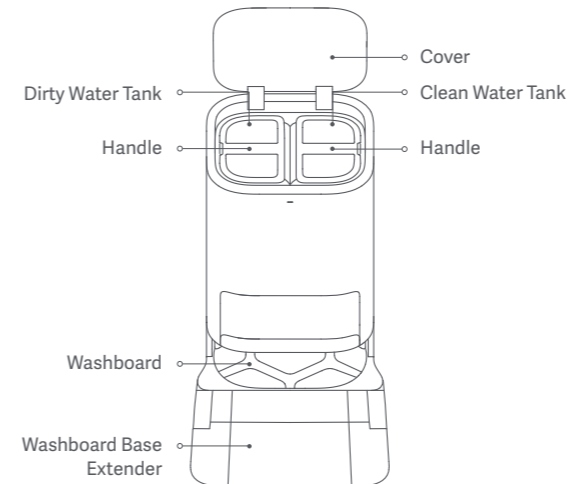

Disposable bag

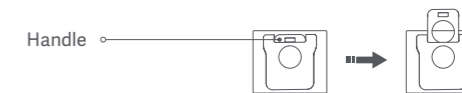
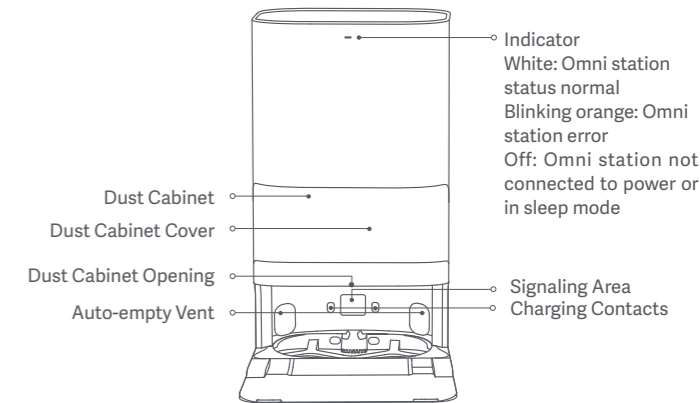

Note: The omni station is pre-installed with a disposable bag when leaving the factory.

How to Install

Removing Protective Coverings

Before using the robot vacuum, remove the protective strips from both sides.

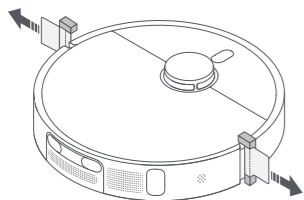

Installing the Side Brush and the Mop Assembly

Install the side brush and the mop assembly respectively as illustrated. They are properly installed when you hear a "click".

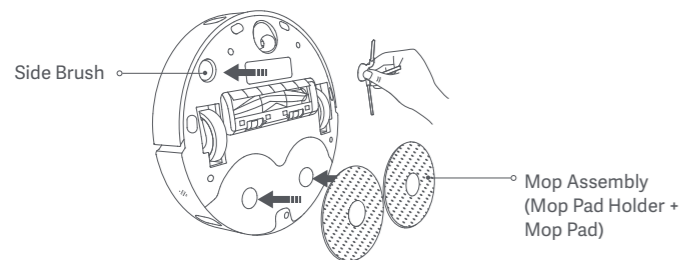

Placing the Omni Station

Place the omni station against a wall on a flat and hard-surfaced floor, such as a wooden or tiled floor. Make sure there is empty space of more than 0.82 meters in height, more than 1.93 meters in length, and more than 0.44 meters in width. Ensure the omni station is in an area with a good Wi-Fi signal near an electrical outlet, and then connect it to power.

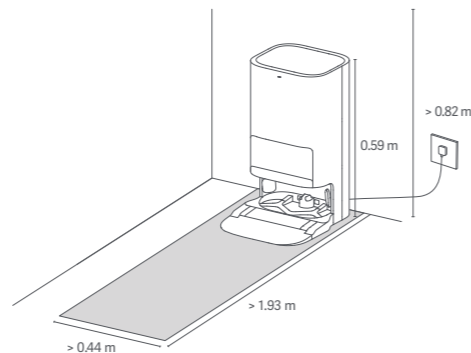

Firmly insert the connector upwards into the power port until the indicator on the station remains white.

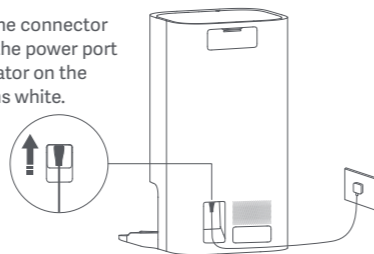

Placing the Robot Vacuum

Before use, press and hold the button  on the robot vacuum for three seconds to turn it on. Once the robot vacuum is on, place it onto the omni station, and make sure the charging contacts on the robot vacuum and the station are fully aligned. The robot vacuum connects to the omni station successfully when you hear a voice prompt for starting charging.

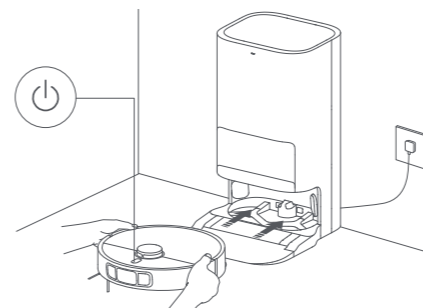

Notes:

- Before the first use, it is recommended to fully charge the robot vacuum. If the robot vacuum cannot be turned on due to low battery level, manually place the robot vacuum onto the omni station to charge it for a while.
- When the robot vacuum is being charged, it will automatically turn on and cannot be turned off.

How to Use

Adding Water to the Clean Water Tank

Fill the clean water tank with clean water up to the maximum water level mark.

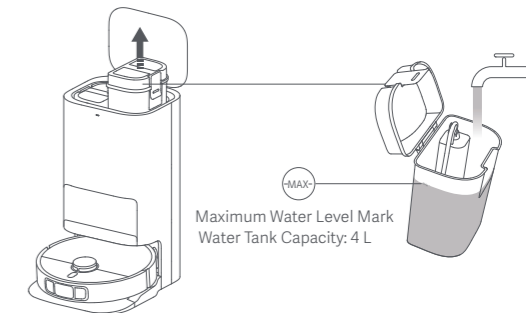

Notes:

- Do not add water above the maximum water level mark (MAX).
- Do not add hot water to the water tank, as this may cause the tank to become deformed.
- Do not add any substance like detergents other than clean water to avoid damaging the robot vacuum.

Connecting with the Mi Home/Xiaomi Home App

This product works with the Mi Home/Xiaomi Home app*. Use the Mi Home/Xiaomi Home app to control your device, and to interact with other smart home devices.

Scan the QR code to download and install the app. You will be directed to the connection setup page if the app is installed already. Or search for "Mi Home/Xiaomi Home" in the app store to download and install it.

Open the Mi Home/Xiaomi Home app, tap "+" on the upper right, and then follow the instructions to add your device.



78FF9E4E

* The app is referred to as Xiaomi Home app in Europe (except for Russia). The name of the app displayed on your device should be taken as the default.

Notes:

- The robot vacuum works with the Mi Home/Xiaomi Home app, and it supports Android 9.0 & iOS 12.0 or above.
- Only 2.4 GHz Wi-Fi networks are supported.
- The version of the app might have been updated, please follow the instructions based on the current app version.

Resetting Wi-Fi

Take the following steps if the robot vacuum cannot be connected to the network because the router is reset, the password is forgotten, or for other reasons:

1. Open the cover of the robot vacuum so that you can see the Wi-Fi indicator.
2. Simultaneously press and hold the buttons and until you hear a voice to indicate that the robot vacuum is waiting for the network configuration.
3. When the Wi-Fi indicator blinks, the Wi-Fi connection has been reset successfully.

Turning On/Off

Press and hold the button for three seconds to turn the robot vacuum on. When the indicator on the robot vacuum lights up, it means the robot vacuum enters the standby mode. When the robot vacuum is paused and not being charged, press and hold the button for three seconds to turn it off.

Note: When the robot vacuum is charging, it will automatically turn on and cannot be turned off.

Quick Map Creation

After configuring the network for the first time, follow the instructions in the app to quickly create a map, and the robot vacuum will start mapping without cleaning. The mapping process will be completed when the robot vacuum returns to the omni station, and the map will be saved automatically.

Pausing

When the robot vacuum is running, press any button to pause it.

Note: Do not lift or move the robot vacuum while it is paused. Otherwise, it may have navigation errors that could prevent the robot vacuum from returning to the omni station or cause the loss of the map.

Sleep Mode

The robot vacuum will automatically enter sleep mode after it is paused for 10 minutes, and its indicator will go out. To wake it up, press any button on the robot vacuum.

Resuming Cleanup

If the robot vacuum starts running low on battery during a cleaning task, it will automatically return to the omni station to charge. When the robot vacuum is fully charged, it will resume cleanup where it left off.

Child Lock Settings

To enable or disable the child lock, press and hold the button on the robot vacuum for three seconds.

Note: When the child lock is enabled, the buttons on the robot vacuum will not work.

Dust Emptying

When the robot vacuum automatically returns to the omni station to charge after completing a vacuuming and mopping task, a vacuuming before mopping task, or a vacuuming task, the omni station will automatically start to empty the dust compartment.

Notes:

- When the robot vacuum returns midway to the omni station to clean mop pads, the station will not automatically empty the dust compartment.
- If the function of auto dust emptying is disabled in the app, the omni station will not automatically empty the dust compartment.

Vacuuming and Mopping

① Start cleaning

Before starting, ensure the mop assembly and other necessary parts have been installed onto the robot vacuum and the clean water tank has been added water. Select the vacuuming and mopping mode in the app, and use the app or press

the button on the robot vacuum to make it start from the station. Then the robot vacuum will plan the optimal cleaning route and perform the cleaning task based on the created map.

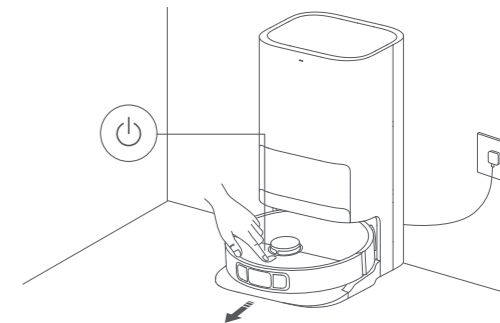

Notes:

- To prevent the carpets from being wet when mopping, you can manually add carpeted areas in the app and select a carpet cleaning method.
- When using the robot vacuum for the first time, it is recommended to follow the robot vacuum throughout the whole process to remove the items that may affect its work.
- If the robot vacuum may get stuck or scratch the surface of furniture in some areas, you can set restricted areas in the app to prevent the robot vacuum from entering these areas.
- When the robot vacuum runs on an area covered with shaggy rugs, in dark environments, or in environments with highly reflective surfaces, its performance may to some extent be affected.
- The robot vacuum will moisten the mop pads before starting, please wait with patience.
- Before starting, ensure the omni station is connected to power and the robot vacuum is connected to the omni station.
- To ensure that the robot vacuum can return to the omni station successfully after completing vacuuming and mopping, it is recommended to make the robot vacuum start from the omni station. Do not move the omni station, the clean water tank, the dirty water tank, or the washboard during cleaning.

② Automatically return to clean mop pads midway

During cleaning, the robot vacuum will automatically return to the omni station to wash the mop pads after it cleans certain squares of area. Once the mop pads have been washed, the robot vacuum will resume its cleaning task.



③ Auto dust emptying & mop pad cleaning and air-drying

Once the robot vacuum has completed its cleaning task and returned to the omni station to charge, the omni station will automatically start emptying dust and then clean and air-dry the mop pads.

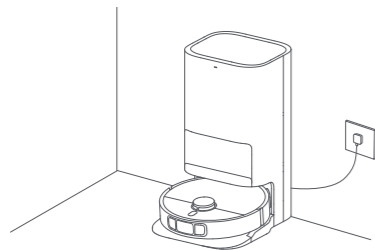

④ Clean the dirty water tank

After the mop pads have been cleaned and air-dried, please clean the dirty water tank in time to prevent odors.

Vacuuming before Mopping

Before starting, ensure the mop assembly has been installed onto the robot vacuum and the clean water tank has been added water. Select the vacuuming before mopping mode in the app, and use the app or press the button  on the robot vacuum to start the cleaning task, then the robot vacuum will lift the mop assembly to vacuum. Once it finishes vacuuming, it will return to the omni station to automatically empty the dust and moisten the mop pads, then it will lower the mop assembly to start mopping.

Vacuuming

Select the vacuuming mode in the app, then use the app or press the button  on the robot vacuum to start cleaning, and the robot vacuum will lift the mop assembly and start from the omni station to vacuum. Once it finishes vacuuming, it will return to the omni station to automatically empty the dust compartment.

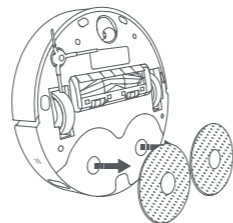

Note: If the mop assembly is not installed, the robot vacuum will automatically perform the vacuuming mode after starting.

Mopping

Before starting, ensure the mop assembly and other necessary parts have been installed onto the robot vacuum and the clean water tank has been added water. Select the mopping mode in the app, and use the app or press the button  on the robot vacuum to start cleaning. Then the robot vacuum will automatically moisten the mop pads first and leave the omni station to start mopping. Once it finishes mopping, it will return to the omni station to wash and air-dry the mop pads.

More App Functions

Map

The homepage of the app displays the current map used for vacuuming and mopping. You can set areas to avoid in the settings for restricted areas and edit the current map in map management.

Cleaning settings

In the cleaning settings, you can adjust the cleaning mode, the suction level, and the water flow rate based on the dirtiness of the floor and specific needs.

Omni station settings

The dust emptying and the mop pad cleaning can be configured in the omni station settings.

In the dust emptying settings, you can enable or disable the function of auto dust emptying and change its frequency.

In the mop pad cleaning settings, you can adjust the frequency at which the robot vacuum returns to the station for cleaning mop pads.

Notes:

- Before using the selected area/zoned cleanup or editing the map, a map needs to be created.
- Please refer to the app for more functions. Details of each function are subject to the app.



Updating the Firmware

You can update the robot vacuum's firmware via the Mi Home/Xiaomi Home app. Before updating, make sure the robot vacuum is on the omni station and its battery level is more than 15%.

Restoring Factory Settings

If the robot vacuum does not function properly after being restarted, you can use a pin to press the reset button for three seconds until you hear a voice to indicate that the robot vacuum is restoring factory settings. This will reset the robot vacuum to its original factory settings.

Restarting the Robot Vacuum

If the robot vacuum stops responding or cannot be turned off, press and hold down the button  for 15 seconds to forcefully turn it off. Then press and hold the button  for three seconds to turn the robot vacuum on.

Care & Maintenance

Parts

To keep the robot vacuum in good condition, it is recommended to refer to the following table for routine maintenance.

Part	Cleaning Frequency	Replacement Frequency
Dust Compartment	Clean as required	/
Filter (Pre-installed on the dust compartment)	Clean every two weeks	3-6 months
Clean Water Tank	Clean every two weeks	/
Dirty Water Tank	Recommended to clean after each use	
Washboard	Clean every 1-2 weeks	
Brush	Clean every two weeks	6-12 months
Side Brush	Clean every two weeks	3-6 months
Mop Pad	/	1-3 months
Caster Wheel	Clean every month	/
LDS Laser Sensor		
Line Laser Sensor		

Part	Cleaning Frequency	Replacement Frequency
Cliff Sensor	Clean every month	/
Robot vacuum's charging contacts		
Bumper		
Auto-empty vents of robot vacuum		
Bottom of the robot vacuum		
Omni station		
Omni station's charging contacts		
Omni station's signaling area		
Disposable bag	/	Replace about every 2.5 months depending on actual use

Notes:

- The replacement frequency is for reference only. If a part is damaged, it should be replaced promptly to ensure efficient cleaning.
- To move or ship the robot vacuum, please empty the clean and dirty water tanks to avoid the robot vacuum getting damaged in transit.

Replacing the disposable bag

- When the disposable bag is full, pull the cover out from the dust cabinet opening. Remove the disposable bag using the handle, and discard it. Then use a dry cloth to wipe away any dirt from the filter.

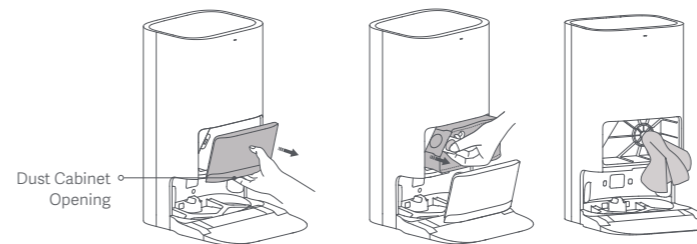

Note: Pulling the handle of the disposable bag will seal the bag to prevent the dust and debris from accidentally falling out.

- Install a new disposable bag as illustrated and insert the handle of the bag into the slot. Then put the dust cabinet cover back, and it is properly installed when you hear a "click".

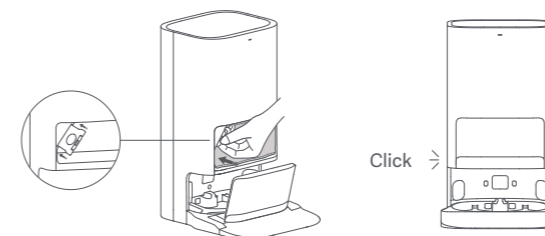

Cleaning the clean and dirty water tanks

- Remove both the clean and dirty water tanks, open their covers, and pour out the water.

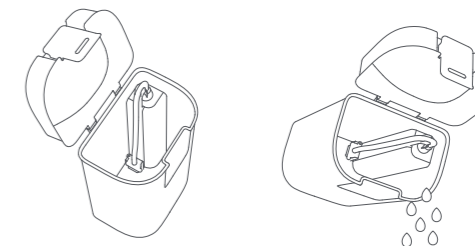

- Use clean water to completely wash the tanks, then wipe the outside of the tanks dry before reinserting them into the omni station.

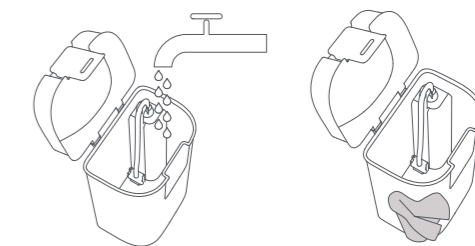

Note: Both the floater in the clean water tank and the float ball in the dirty water tank are movable parts. Do not apply too much force when cleaning them to avoid damaging them.

Cleaning the washboard and washboard base

1. Select the omni station cleaning function in the app and the robot vacuum will automatically leave the omni station. Manually remove the washboard, and then the omni station will automatically inject water into the washboard base. Use a cloth or brush to clean any dirt from the base and washboard.

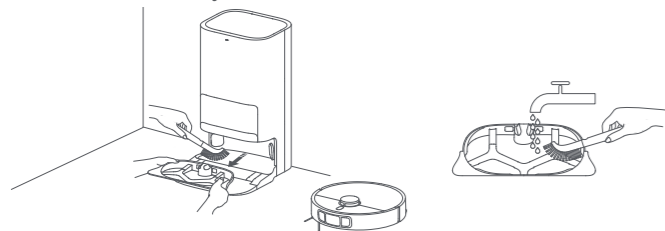

2. Wait for three minutes and the omni station will automatically drain away the dirty water. Use a dry cloth to wipe clean the washboard base and the washboard, then reinstall the washboard. Once the base has been cleaned, you can manually place the robot vacuum onto the omni station, use the app, or press the button  on the robot vacuum to send it back.

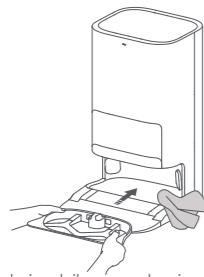

Note: Do not tilt the omni station during daily use or cleaning. If water collects in the washboard base, wipe it dry with a cloth.

Cleaning sensors and charging contacts

Use a soft cloth to clean all sensors and charging contacts in the robot vacuum:

- The cliff sensors on the bottom of the robot vacuum.
- The charging contacts on the back of the robot vacuum.
- The LDS laser sensor on the top of the robot vacuum.
- The bumper and the line laser sensor on the front of the robot vacuum.

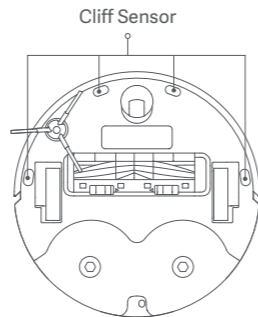
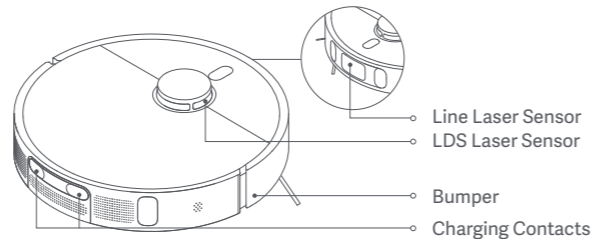

Cleaning the brush and side brush

1. Flip the robot vacuum over and pinch the clips to remove the brush cover.
2. Lift the brush out, remove the bearings on both ends, and clean the brush's axle.
3. Use scissors to cut any hair tangled around the brush, and remove any debris.
4. Pull out the side brush upwards and clean it.
5. Reinstall the side brush, brush and brush cover, and ensure they are securely in place.

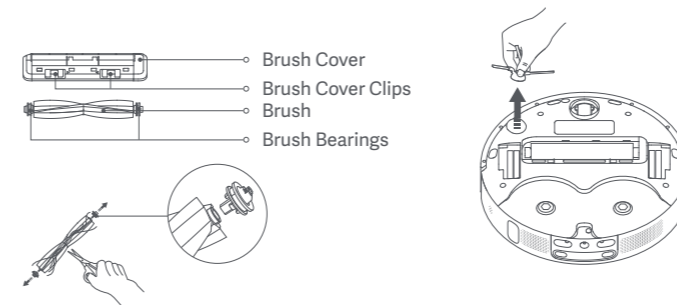

CAUTION: If too much hair is tangled in the brush, or if the hair is tightly tangled, do not forcibly pull on it, as this could damage the brush.

Cleaning the caster wheel

1. Flip the robot vacuum over and pull out the caster wheel.
2. Remove hair, dirt, and other debris from the wheel and axle.
3. Reinsert the caster wheel and press it firmly back into place.

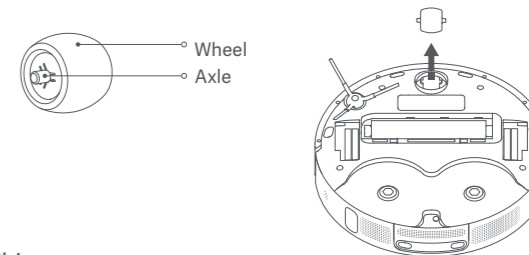

Notes:

- A small screwdriver or other pry tool can be used to gently pop out and remove the wheel.
- The wheel can be cleaned with water and reinstalled after drying.

Cleaning the omni station

Clean the charging contacts, the auto-empty vents, and the signaling area of the omni station with a soft, dry cloth.



Battery

The robot vacuum contains a high-performance lithium-ion battery pack. Please ensure that it remains well-charged during daily use to maintain optimal battery performance.

Note: If the robot vacuum is not used for an extended period, turn it off and put it away. To prevent damage from over-discharging, the robot vacuum should be recharged at least once every three months.