



JD57 Series

Integrated Close- Loop Step Motor Manual (PULSE CONTROL)

【 Please read the manual in detail before use, to avoid damage to the motor 】

Lishui City Hengli Automation Technology Co., Ltd.

Add:No. 83, Yunjing Road, Shuige, Liandu District, Lishui City

Zhejiang,China

Postcode:323000

Tel: +86-13884328311

Email:hltn2020@gmail.com

Web:<https://gopower.en.alibaba.com/>



CONTENTS

PREFACE	3
SAFETY RECAUTIONS	3
1.PRODUCT INTRODUCTION	6
1.1. OUTLINE	6
1.2. FEATURES	6
1.3. APPLICATION	6
2. ELECTRICAL, ENVIRONMENTAL INDEX.....	7
2.1. ELECTRICAL INDEX	7
2.2. ENVIROMENTAL INDEX	7
2.3. INSTALLATION DIAGRAM	7
2.4. INSTALLATION	8
3. DRIVER INTERFACE AND WIRING	9
3.1. INTERFACE DEFINITION	9
3.2. CONTROL SIGNAL WIRING.....	10
3.3. OUTPUT SIGNAL WIRING	12
3.4. STATUS INDICATOR LED.....	12
4. DIP SWITCH SETTING	13
4.1. STEP RESOLUTION SETTING	13
4.2. MOTOR ROTATION DIRECTION SETTING	14

PREFACE

Thanks for choosing JD57 series closed-loop integrated stepper motors. This manual describes the installation, debugging, maintenance, operation and other aspects of the integrated step-servo motor JD57. Please read this manual in detail before use, and be familiar with the safety precautions. This manual may be revised timely when product is improved, specifications and version are changed or for some other reasons, which will not be notified again. Any questions when using our products, please read the relevant manual or call our technical service department, we will meet your requirements in the shortest possible time.

Marks and warning signal:



Danger: Indicates that this operation error may endanger personal safety!



Attention: Indicates that this operation error may result in equipment damage!

SAFETY PRECAUTIONS

Open Box and Check



Do not install integrated step-servo motor which is damaged or with missing parts.

Installation



Installed on a non-flammable metal frame, prevent the intrusion of dust, corrosive gases, conductive objects, liquids and flammable materials, and maintain good heat dissipation conditions



During installation, be sure to tighten the mounting screws of the integrated step-servo motor. It should be protected from vibration and shock.

Wiring





Please perform the wiring work by professional electrical engineer;



Before wiring, please confirm that the input power is off. Wiring and inspection must be performed after the power is turned off and the integrated step-servo motor indicator is off to prevent electric shock;

 When plugging and unplugging the integrated step-servo motor terminals, make sure that its indicator is off before proceeding;

 Please set the emergent stop circuit outside the controller;

 Please tighten the output terminal with a suitable torque.

Electrify

 Please confirm whether the main circuit input power is consistent with the rated working voltage of the integrated step-servo motor;

 Do not test the integrated step-servo motor for high voltage and insulation resistance at will;

 Do not connect the electromagnetic contactor or electromagnetic switch to the output circuit.

Operation

 Do not directly touch the output terminals after the integrated step-servo motor is powered on;

 When the system is running, the integrated step-servo motor may have a high temperature rise, do not touch it;

 Please confirm the input and output signals to ensure safe operation;

 The alarm can be reset only after the operation signal is cut off. Alarm resetting in the running signal state will cause the integrated step-servo motor to restart suddenly;

 Do not change the parameter settings of the integrated step-servo motor at will. The parameter modification needs to be performed under standby condition.

Maintenance and Inspection

 Do not touch the integrated step-servo motor terminals directly, and some have high voltage, very dangerous;

 Before powering up, be sure to install the cover; when removing the cover, be sure to cut off the power supply first;

 Before wiring, please confirm whether the input power is off;

 After cutting off the main circuit input power and confirming the integrated step-servo motor indicator light has completely extinguished, it can be inspected and maintained;

 Do the inspection and maintenance by professional electrical engineer;



Do not do wiring, disassembling or other operation on the terminals during power on.



There is an integrated circuit on the main control board of the integrated step-servo motor. Please pay full attention when checking to avoid damage caused by static induction.

1. PRODUCT INTRODUCTION

1.1. Outline

JD57 is a 2 phase hybrid open loop stepper motor with high-performance digital integrated driver. The system structure is simple and the integration is high. This series of integrated step-servo motor adopt the latest 32-bit motor control dedicated DSP chip, and uses advanced digital filter control technology, resonant vibration suppression technology and precision current control technology to achieve accurate and smooth operation. It's featured with high torque output, low noise, low vibration and low heat, making it ideal for electronic processing equipment, laser processing, medical and small CNC equipment.

1.2. Features

- Ultra-low vibration and low noise;
- Maximum 512 microstep subdivision, minimum unit 1;
- Input voltage: 24V- 48VDC;
- 3 isolated differential signal input ports: 5VDC-24VDC;

- 1 isolated output port: alarm output, OC;
- 4 DIP switch selection, 16-segment step resolution;
- Automatic flow reduction function: 50%;

1.3. Application

Suitable for all kinds of small automation equipment and instruments, such as: pneumatic marking machine, labeling machine, cutting machine, laser marking machine, plotter, small engraving machine, CNC machine tool, pick and place device. It is particularly effective in applications where users expect low noise, low vibration, high stationarity and high precision.

2. ELECTRICAL, ENVIRONMENTAL INDEX

2.1. Electrical Index

Driver Parameter	Min value	Typical value	Max value	Unit
Input voltage	20 VDC	24VDC	50VDC	V
Output current(peak)	0	3.2	4.0	A
Step signal frequency	0	-	200K	Hz
Control signal input current	7	10	16	ma
Over-voltage protection	-	55	-	VDC
Input signal voltage	5	5	24	VDC
Insulation resistance	100	-	-	M Ω

Holding torque	L=76mm		2.2	N
	L=100mm		2.8	

2.2 Environmental indicators

Cooling Type		Natural cooling or forced cooling
Working environment	Application occasion	Avoid dust, oil mist and corrosive gases
	Working temperature	0~50℃
	Max. ambient humidity	90% RH (no condensation)
	Storage temperature	-10~70℃
	Vibration	10~55Hz/0.15mm

2.3 Installation Diagram

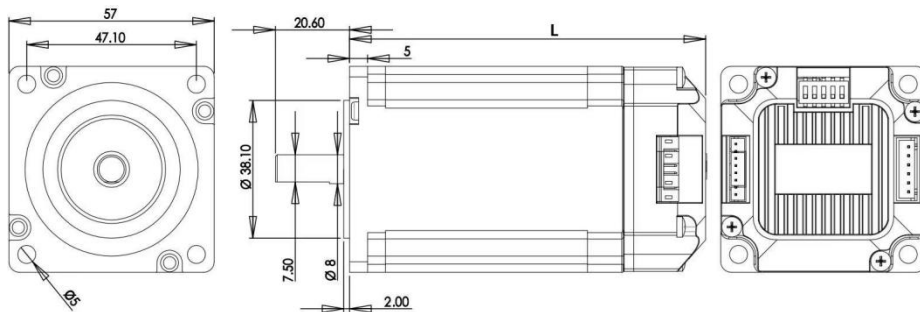

Fig.1 Installation dimension diagram (Unit: mm)

2.4 Installation

User could mount with the mounting holes on the front of the integrated step-servo motor. Use M4 screw to install through the holes in the four corners.

The integrated step-servo motor will generate heat. If continuous operation is under high input voltage and high power conditions, the effective heat dissipation area or forced cooling should be expanded. Do not use in places where air is not circulating or where the ambient temperature exceeds 60℃; do not install it in a place that is wet or has metal shavings.

3. DRIVER INTERFACE AND WIRING

3.1. Interface Definition

3.1.1 Power and controller port

Mark	Name	Function
VCC+	Power interface	Power supply 24-48V
GND		
PUL+	Pulse input	Pulse control ports,it Can be 5V to 24V
PUL-		
DIR+	Direction input	Direction control ports,it Can be 5V to 24V
DIR-		
ENA+	Enable input	Enable control ports,it Can be 5V to 24V
ENA-		
ALM+	Alarm input	Photoelectric isolation OC output
ALM-		

3.2 Control Signal Wiring

If input control signal is differential, its control signal interface wiring diagram is shown in Figure 2.

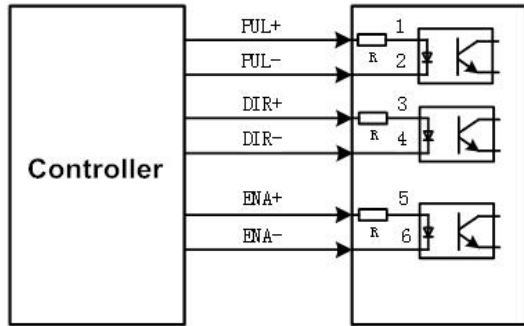
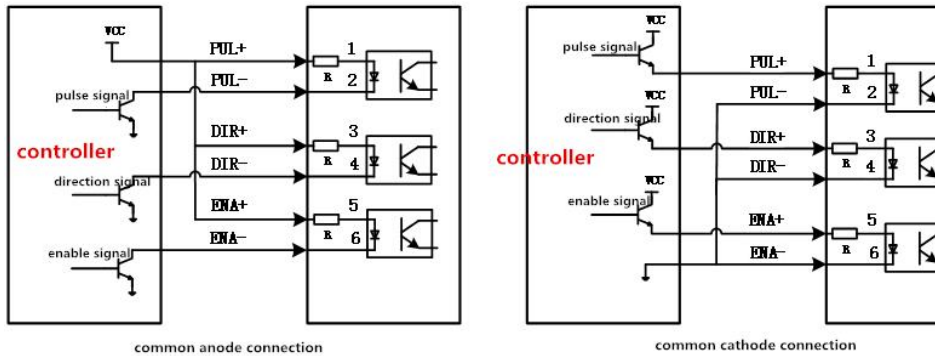

Fig.2 Control signal interface wiring diagram

If input control signal single-ended, its control signal interface wiring diagram is shown in Figure 3:



Control signal timing diagram

In order to avoid some wrong actions and deviations, PUL, DIR and ENA should meet

certain requirements, as shown below:

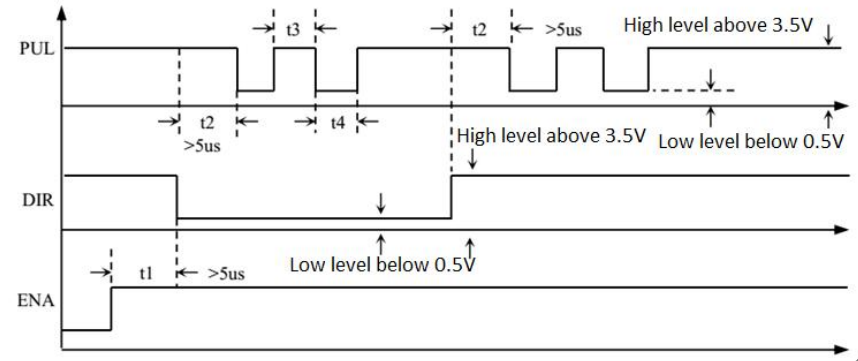

Fig.4 Control signal timing diagram

Note:

- 1) t1: ENA (enable signal) should be confirmed to be high at least 100ms ahead of DIR, to ensure that the brake is open, and the motor enters running state, to avoid abnormality.
- 2) t2: DIR is confirmed for its state to be high or low at least 5 μ s ahead of PUL falling edge.
- 3) t3: The pulse width is at least not less than 2.5 μ s.
- 4) t4: The low level width is not less than 2.5 μ s.

3.3. Output Signal Wiring

Signal output wiring, such as alarm signal output ALM, photoelectric isolation OC output, maximum withstand voltage 30VDC, maximum saturation current 50mA.

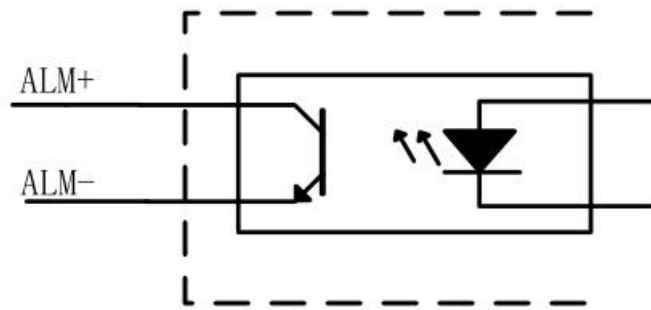

Fig.5 Output Signal Wiring

3.4. Status Indicator LED

The green LED is the power indicator, which is always on when the driver is powered up; it is off when the driver is powered off. The red LED is the fault indicator. When the driver fails, it will stop and prompt the corresponding fault code. The fault can be cleared when the user needs to power off and restart the power. The status indicator LED represents different operation and fault information, as shown in the following table:

Status	Condition	Status indicator LED description	
over-voltage	Power supply voltage exceeds maximum rated voltage	1 red	
over-current	The phase current through the motor exceeds the rated current or the phase-to-phase short circuit	2 red	
out-of-tolerance	Position out of tolerance	3 red	
parameter read error	EEPROM read error	4 red	
internal reference error	Driver internal fault	5 red	

4. DIP SWITCH SETTING

JD57 uses a five-digit dial switch, set the step resolution accuracy and motor rotate direction. The detailed description is as follows:

Mark	Function
SW2 SW3 SW4 SW5	Step Resolution Accuracy Setting
SW1	Motor Rotation Direction Selection

4.1. Step resolution Setting

The step resolution parameters can be customized according to customer requirements, ranging from 400 to 51200 Step/Rev. For example, the default is the following table.

SW2	SW3	SW4	SW5	Step/Rev
ON	ON	ON	ON	400
OFF	ON	ON	ON	800
OFF	ON	ON	ON	1600

OFF	OFF	OFF	ON	3200
ON	ON	OFF	ON	6400
OFF	ON	OFF	ON	12800
ON	OFF	OFF	ON	25600
OFF	OFF	OFF	ON	51200
ON	ON	ON	OFF	1000
OFF.	ON	ON	OFF	2000
ON	OFF	ON	OFF	4000
OFF	OFF	ON	OFF	5000
ON	ON	OFF	OFF	8000
OFF	ON	OFF	OFF	10000
ON	OFF	OFF	OFF	20000
OFF	OFF	OFF	OFF	40000

4.2. Motor Rotation Direction Setting

SW1=off, the motor rotates counterclockwise (CCW);

SW1=on, clockwise rotation (CW).